

# Spicer® Agricultural Modular Axles

33 to 301 kW (45 to 410 hp)



**SPICER®**

*Off-Highway Systems*

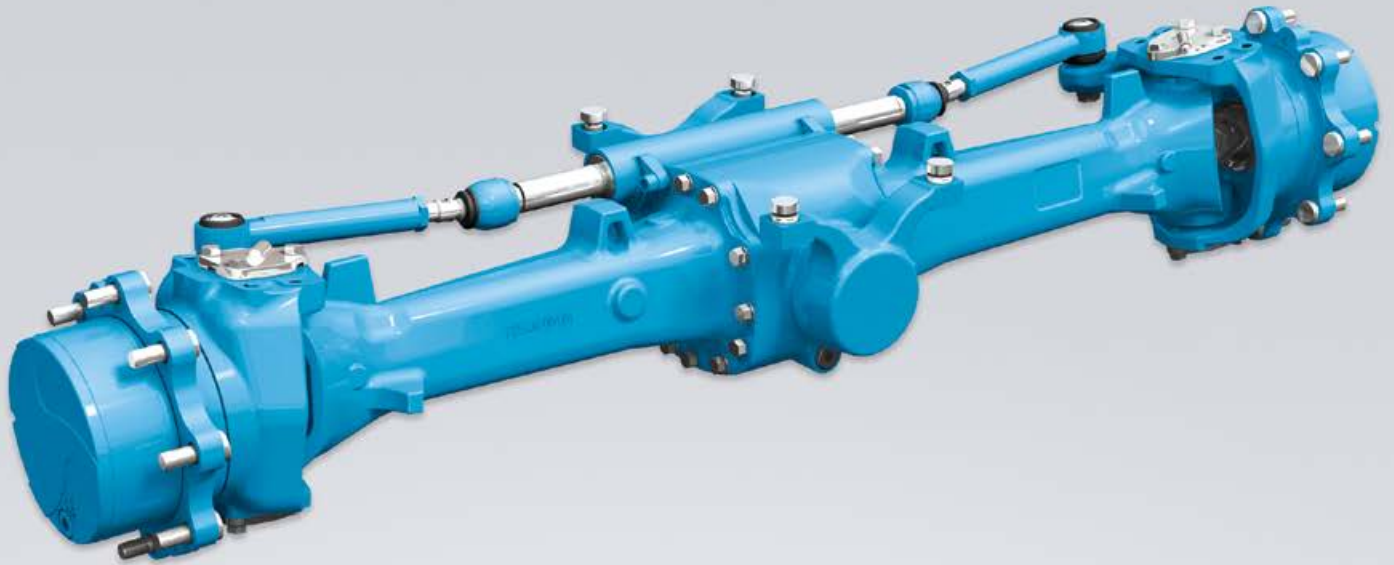

A modular axle design accommodating the full range of agricultural equipment and with a wide variety of customization options to provide machine designers with complete flexibility and faster speed to market.



# Spicer® Agricultural Modular Axles

33 to 301 kW (45 to 410 hp)

Spicer® agricultural modular axles are specifically engineered for a variety of vehicles including tractors, combines, and forage harvesters with power outputs ranging from 33 to 301 kW (45 to 410 hp). A three-piece modular configuration allows greater customization in trumpet housings while maintaining its core components. Braking, steering sensors, application seals, and other mechanical hydraulic locking differential options are also available to tailor each axle based on local machining specifications.

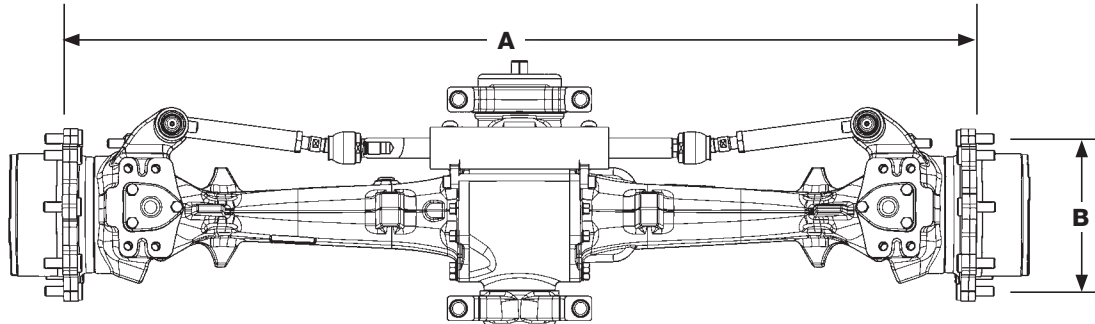

## Design Features

<b>Axle Mounting</b>	High pivot or central trunnion
<b>Input Flange Options</b>	DIN, end yoke
<b>Double Reduction Planetary Wheel End</b>	Single reduction
<b>Service Brakes</b>	Available as option
<b>Differential Options</b>	Limited slip, 100% dog clutch, 100% multidisc

## AGRICULTURAL MODULAR AXLES

Product Model	Generic Designation	Engine HP	Max Output		Available Planetary Ratio	Ratio Range (Overall)	Steer Angle	Flange to Flange A		BCD B	Brakes	Multidisc Differential Lock
			Nm	ft-lb				mm	inch			
10	M10	45 – 65	9,200	6780	1:4.235	11.55 to 14.585	55°	1580	62	205	No	No
20	M20	65 – 90	13,000	9580	1:6	11.571 to 17	55°	1640	64	275	Yes	Yes
25	M25	90 – 105	16,000	11,800	1:6	11.571 to 17	55°	1640	64	275	Yes	Yes
30	M30	105 – 125	21,000	15,480	1:6	14.571 to 17	55°	1640	64	275	Yes	Yes
40	M40	125 – 140	27,000	19,910	1:6	13.827 to 17.538	55°	1640 to 1800	64 to 70	275	Yes	Yes
50	M50	140 – 220	42,000	30,970	1:6.353	13.827 to 17.104	55°	1780 to 1900	70 to 74	335	Yes	Yes
60	M60	220 – 280	55,000	40,560	1:6.353	13.82 to 18.15	55°	1780 to 1900	70 to 74	335	Yes	Yes
70	M70	300 – 410	80,000	59,000	1:7.07	16.97	55°	1900	74	425	Yes	Yes

Dana Italia Spa  
Via Linfano  
38062 – Arco (TN)  
Italy

[www.dana.com/offhighway](http://www.dana.com/offhighway)



**SPICER®**

Off-Highway Systems

### Application Policy

Capacity ratings, features, and specifications vary depending upon the model and type of service. Application approvals must be obtained from Dana; contact your representative for application approval. We reserve the right to change or modify our product specifications, configurations, or dimensions at any time without notice.