



**YANMAR TRACTOR (U.S.A.), INC.**

**TRACTOR HYDRAULIC VALVE STAND KIT  
TVS K-3  
FOR THE  
276 TRACTOR**



**YANMAR TRACTOR (U.S.A.), INC.**



TRACTOR HYDRAULIC VALVE STAND KIT NO. TVS K-3

Loader Control Valve

For valve components or associated Hydraulic hoses, fittings and Quick Disconnect Couplers, refer to Hydraulic Valve Kit No. HYD K-1 Parts List.

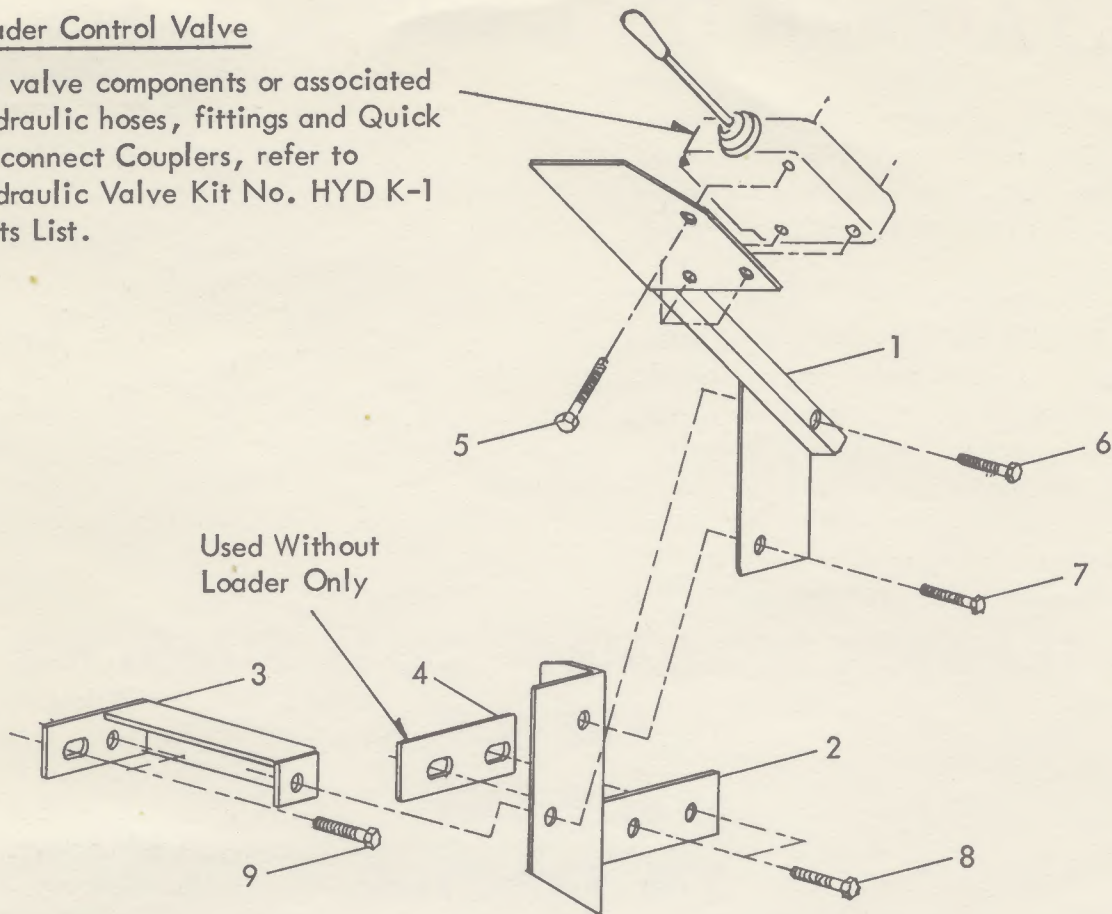

ITEM	PART NO.	DESCRIPTION	QTY.
1	212501	Valve Stand	1
2	212535	Valve Stand Mounting Bracket	1
3	212536	Valve Stand Support Bracket	1
4	212503	Spacer - (Plate)	1
5	006882	Capscrew - 3/8" - 16 x 2-1/2" Lg.	3
	008079	Lockwasher 3/8"	3
	007451	Hex Nut 3/8" - 16	3
6	542-2112	Capscrew - 1/2" - 13 x 3" Lg.	1
	008101	Lockwasher 1/2"	1
	007501	Hex Nut 1/2" - 13	1
7	007015	Capscrew - 1/2" - 13 x 1-3/4" Lg.	1
	008171	Flatwasher 1/2"	1
	008101	Lockwasher 1/2"	1
	007501	Hex Nut 1/2" - 13	1
8	26116-120402	Capscrew - 12 mm x 1.75 mm x 40 mm Lg.	2
	22117-120000	Lockwasher 12 mm	2
9	26116-080302	Capscrew - 8 mm x 1.25 mm x 30 mm Lg.	2



## VALVE STAND KIT INSTALLATION

Using the two existing threaded holes in side of clutch housing install the Valve Stand Mounting Bracket using two 12 mm x 1.75 mm x 40 mm Capscrews, and 12 mm Lockwashers.

### NOTE:

i) Valve Stand Bracket Spacer (Plate) must be positioned between Valve Stand Mounting Bracket and clutch housing EXCEPT when mounted on tractor in combination with a loader. When tractor is equipped with a loader discard Spacer Plate as Loader Rear Mount Mounting Plate is located between Valve Stand Bracket and transmission case.

ii) Do not tighten 12 mm capscrews until Valve Stand Support Bracket is in place.

Remove and discard the two existing 8 mm x 1.25 mm x 16 mm Capscrews used to secure the instrument panel support to the clutch housing. Install the Valve Stand Support Bracket using two 8 mm x 1.25 mm x 30 mm Capscrews and 8 mm Lockwashers (reuse original Lockwashers).

Install the Valve Stand using one 1/2" - 13 x 3" Capscrew, 1/2" Lockwasher and 1/2" Hex Nut in the upper mounting hole and one 1/2" - 13 x 1-3/4" Capscrew, 1/2" Flatwasher, 1/2" Lockwasher and 1/2" Hex Nut in lower hole.

NOTE: The 1/2" - 13 x 1-3/4" Capscrew secures the Valve Stand and Valve Stand Support Bracket to the Valve Stand Mounting Bracket.

Torque mounting hardware as follows:

8 mm Capscrews - 18ft./lbs. (25 Nm, 2.5 Kgm.).

12 mm Capscrews - 59ft./lbs. (80 Nm, 8 Kgm.).

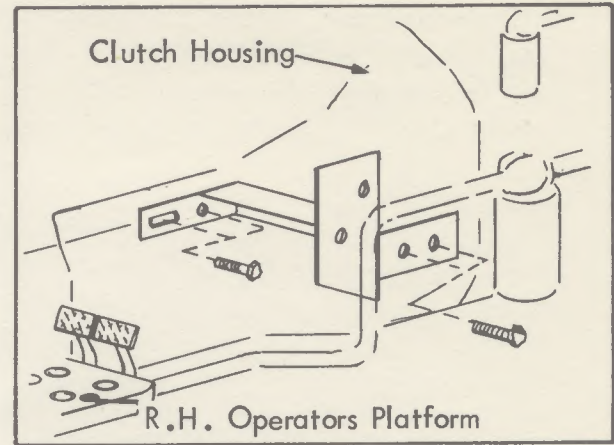

Install the Hydraulic Control Valve on the Valve Stand as outlined in Assembly Instructions contained in Hydraulic Control Valve Kit.

NOTE: Use the three 3/8" - 16 x 2-1/2" Capscrews, 3/8" Lockwashers and 3/8" - 16 Hex Nuts supplied in Valve Stand Kit to mount Control Valve to valve stand.

Following Control Valve installation position the valve stand to place the Control Lever in desired location for operators convenience and torque the two 1/2" Capscrews securing Valve Stand to Valve Stand Mounting Bracket to 55ft./lbs. (75 Nm, 7.5 Kgm.).

